



Micro Commercial Components  
 21201 Itasca Street Chatsworth  
 CA 91311  
 Phone: (818) 701-4933  
 Fax: (818) 701-4939

# MMBD4148CC

**High Conductance  
 Ultra Fast Diode  
 350mW**

## Features

- Surface Mount Package Ideally Suited for Automatic Insertion
- 150°C Junction Temperature
- High Conductance

## Mechanical Data

- Case: SOT-23, Molded Plastic
- Terminals: Solderable per MIL-STD-202, Method 208
- Marking: D5
- Weight: 0.008 grams ( approx.)

## Maximum Ratings @ 25°C Unless Otherwise Specified

Characteristic	Symbol	Value	Unit
Working Inverse Voltage	$V_{IV}$	75	V
DC Forward Current	$I_{FM}$	600	mA
Average Rectified Current	$I_{F(AV)}$	200	mA
Recurrent Peak Forward Current	$I_{FRM}$	700	mA
Peak Forward Surge Current @ $t=1.0s$ @ $t=1.0\mu s$	$I_{FSM}$	1.0 2.0	A
Power Dissipation	$P_d$	350	mW
Thermal Resistance	R	357	°C/W
Operation & Storage Temp. Range	$T_j, T_{STG}$	-55 to +150	°C

**Note:** 1) These ratings are based on a max. junction temperature of 150 degrees C  
 2) These are steady state limits. The factory should be consulted on applications involving pulsed or low duty cycle operation

## Electrical Characteristics @ 25°C Unless Otherwise Specified

Charateristic	Symbol	Min	Max	Unit	Test Cond.
Breakdown Voltage	$V_R$	75		V	$I_R=100\mu A$
Maximum Instantaneous Forward Voltage	$V_F$		1.0	V	$I_F=10mA$
Maximum Instantaneous Reverse Current	$I_R$		25 50 5.0	nA uA uA	$V_R=20V, T_A=150^\circ C$ $V_R=75V$
Junction Capacitance	$C_j$		4	pF	$V_R=0V, f=1.0MHz$
Reverse Recovery Time	$t_{rr}$		4	ns	$I_F=10mA, V_R=6.0V,$ $I_{RR}=1.0mA,$ $R_L=100 OHM$

## SOT-23

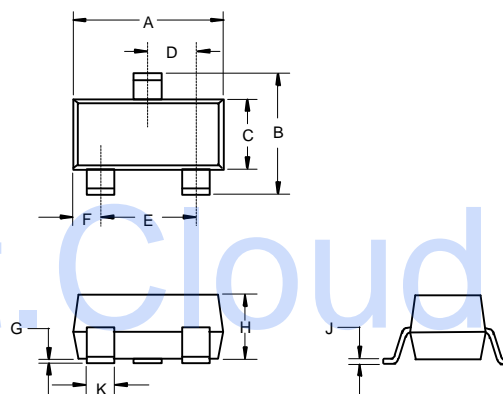

DIM	INCHES		MM		NOTE
	MIN	MAX	MIN	MAX	
A	.110	.120	2.80	3.04	
B	.083	.098	2.10	2.64	
C	.047	.055	1.20	1.40	
D	.035	.041	.89	1.03	
E	.070	.081	1.78	2.05	
F	.018	.024	.45	.60	
G	.0005	.0039	.013	.100	
H	.035	.044	.89	1.12	
J	.003	.007	.085	.180	
K	.015	.020	.37	.51	

## Suggested Solder Pad Layout

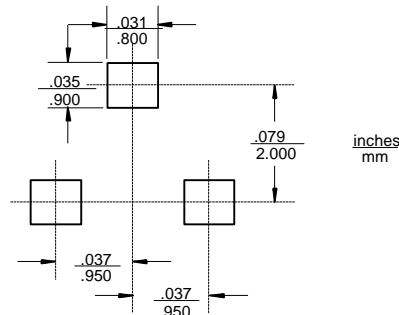

MMBD4148CC

