



# MC1741C

## Internally Compensated, High Performance Operational Amplifier

The MC1741C was designed for use as a summing amplifier, integrator, or amplifier with operating characteristics as a function of the external feedback components.

- No Frequency Compensation Required
- Short Circuit Protection
- Offset Voltage Null Capability
- Wide Common Mode and Differential Voltage Ranges
- Low Power Consumption
- No Latch Up

### MAXIMUM RATINGS

Rating	Symbol	Value	Unit
Power Supply Voltage	$V_{CC}, V_{EE}$	$\pm 18$	Vdc
Input Differential Voltage	$V_{ID}$	$\pm 30$	V
Input Common Mode Voltage (Note 1)	$V_{ICM}$	$\pm 15$	V
Output Short Circuit Duration (Note 2)	$t_{SC}$	Continuous	
Operating Ambient Temperature Range	$T_A$	0 to +70	$^{\circ}C$
Storage Temperature Range	$T_{stg}$	-55 to +125	$^{\circ}C$

NOTES: 1. For supply voltages less than +15 V, the absolute maximum input voltage is equal to the supply voltage.  
 2. Supply voltage equal to or less than 15 V.

### OPERATIONAL AMPLIFIER

#### SEMICONDUCTOR TECHNICAL DATA



P1 SUFFIX  
PLASTIC PACKAGE  
CASE 626



D SUFFIX  
PLASTIC PACKAGE  
CASE 751  
(SO-8)

### PIN CONNECTIONS

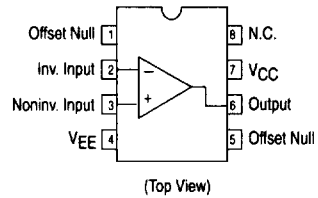

Equivalent Circuit Schematic  
(1/4 of Circuit Shown)

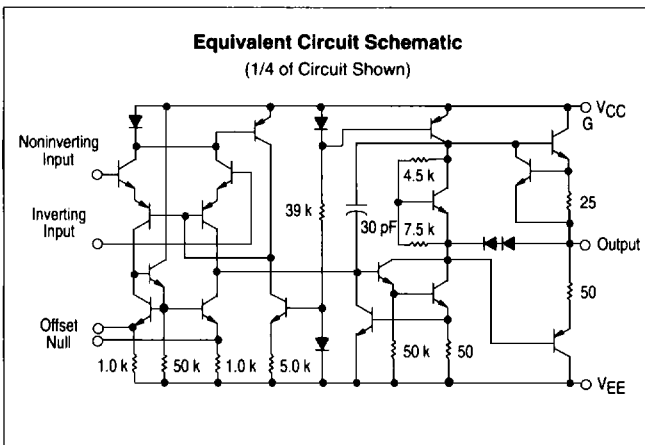

### ORDERING INFORMATION

Device	Alternate	Operating Temperature Range	Package
MC1741CD	-	$T_A = 0^{\circ}$ to $+70^{\circ}C$	SO-8
MC1741CP1	LM741CN $\mu A741TC$		Plastic DIP

**ELECTRICAL CHARACTERISTICS** ( $V_{CC} = +15\text{ V}$ ,  $V_{EE} = -15\text{ V}$ ,  $T_A = 25^\circ\text{C}$ , unless otherwise noted.)

Characteristic	Symbol	Min	Typ	Max	Unit
Input Offset Voltage ( $R_S \leq 10\text{ k}$ )	$V_{IO}$	–	2.0	6.0	mV
Input Offset Current	$I_{IO}$	–	20	200	nA
Input Bias Current	$I_{IB}$	–	80	500	nA
Input Resistance	$r_i$	0.3	2.0	–	M $\Omega$
Input Capacitance	$C_i$	–	1.4	–	pF
Offset Voltage Adjustment Range	$V_{IOR}$	–	$\pm 15$	–	mV
Common Mode Input Voltage Range	$V_{ICR}$	$\pm 12$	$\pm 13$	–	V
Large Signal Voltage Gain ( $V_O = \pm 10\text{ V}$ , $R_L > 2.0\text{ k}$ )	$A_{VOL}$	20	200	–	V/mV
Output Resistance	$r_o$	–	75	–	$\Omega$
Common Mode Rejection ( $R_S \leq 10\text{ k}$ )	CMR	70	90	–	dB
Supply Voltage Rejection ( $R_S \leq 10\text{ k}$ )	PSR	75	–	–	dB
Output Voltage Swing ( $R_L \geq 10\text{ k}$ ) ( $R_L \geq 2.0\text{ k}$ )	$V_O$	$\pm 12$ $\pm 10$	$\pm 14$ $\pm 13$	– –	V
Output Short Circuit Current	$I_{SC}$	–	20	–	mA
Supply Current	$I_D$	–	1.7	2.8	mA
Power Consumption	$P_C$	–	50	85	mW
Transient Response (Unity Gain, Noninverting) ( $V_I = 20\text{ mV}$ , $R_L \geq 2.0\text{ k}$ , $C_L \leq 100\text{ pF}$ ) Rise Time ( $V_I = 20\text{ mV}$ , $R_L \geq 2.0\text{ k}$ , $C_L \leq 100\text{ pF}$ ) Overshoot ( $V_I = 10\text{ V}$ , $R_L > 2.0\text{ k}$ , $C_L \leq 100\text{ pF}$ ) Slew Rate	$t_{LH}$ os SR	– – –	0.3 15 0.5	– – –	$\mu\text{s}$ % V/ $\mu\text{s}$

**ELECTRICAL CHARACTERISTICS** ( $V_{CC} = +15\text{ V}$ ,  $V_{EE} = -15\text{ V}$ ,  $T_A = T_{low}$  to  $T_{high}$ , unless otherwise noted.)\*

Characteristic	Symbol	Min	Typ	Max	Unit
Input Offset Voltage ( $R_S \leq 10\text{ k}\Omega$ )	$V_{IO}$	–	–	7.5	mV
Input Offset Current ( $T_A = 0^\circ$ to $+70^\circ\text{C}$ )	$I_{IO}$	–	–	300	nA
Input Bias Current ( $T_A = 0^\circ$ to $+70^\circ\text{C}$ )	$I_{IB}$	–	–	800	nA
Supply Voltage Rejection ( $R_S \leq 10\text{ k}$ )	PSR	75	–	–	dB
Output Voltage Swing ( $R_L \geq 2.0\text{ k}$ )	$V_O$	$\pm 10$	$\pm 13$	–	V
Large Signal Voltage Gain ( $R_L \geq 2.0\text{ k}$ , $V_O = \pm 10\text{ V}$ )	$A_{VOL}$	15	–	–	V/mV

\*  $T_{low} = 0^\circ\text{C}$      $T_{high} = 70^\circ\text{C}$

Figure 1. Burst Noise versus Source Resistance

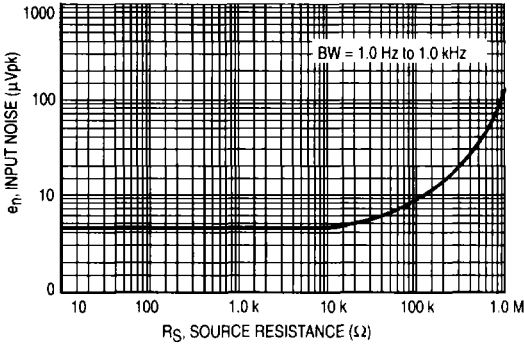
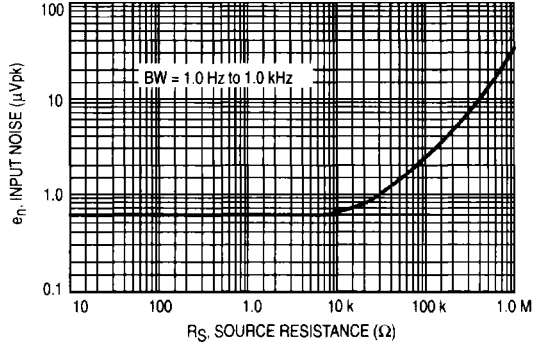

Figure 2. RMS Noise versus Source Resistance



2

Figure 3. Output Noise versus Source Resistance

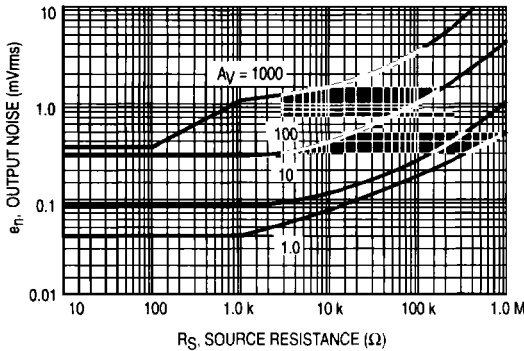

Figure 4. Spectral Noise Density

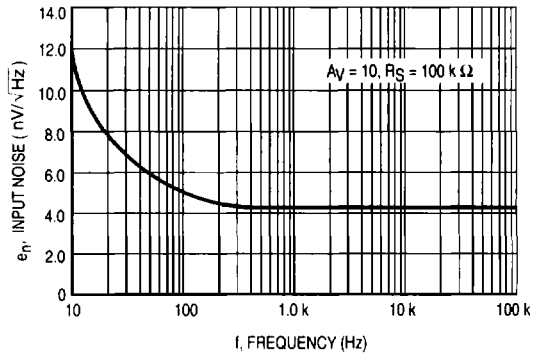
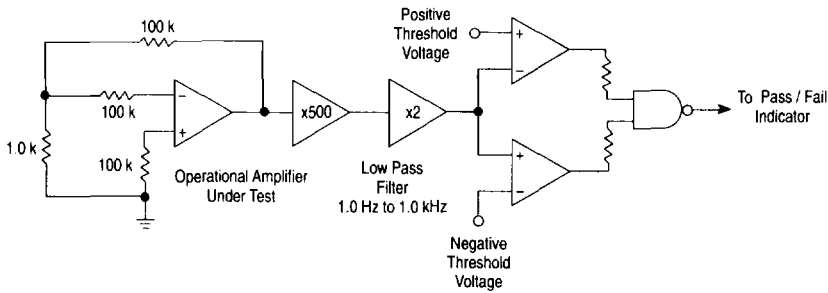

Figure 5. Burst Noise Test Circuit



Unlike conventional peak reading or RMS meters, this system was especially designed to provide the quick response time essential to burst (popcorn) noise testing.

The test time employed is 10 sec and the 20 mV peak limit refers to the operational amplifier input thus eliminating errors in the closed loop gain factor of the operational amplifier.

2

**Figure 6. Power Bandwidth  
(Large Signal Swing versus Frequency)**

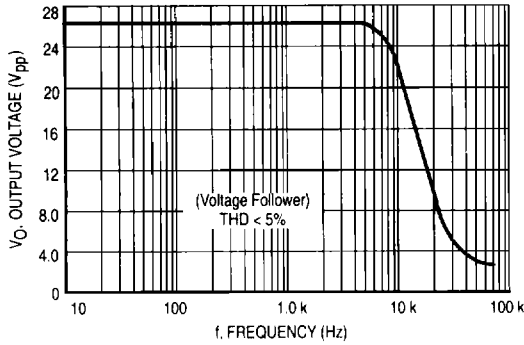

**Figure 7. Open Loop Frequency Response**

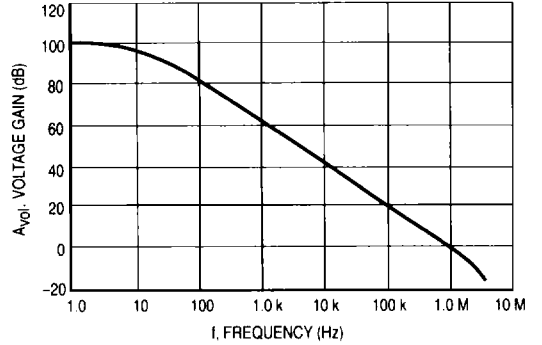

**Figure 8. Positive Output Voltage Swing  
versus Load Resistance**

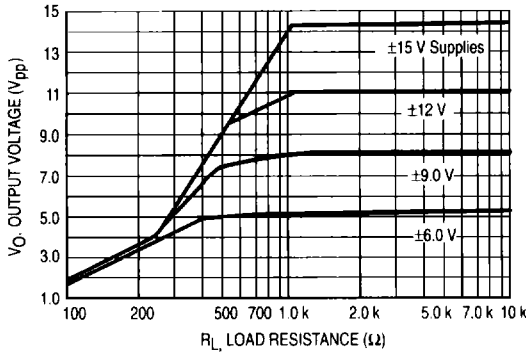

**Figure 9. Negative Output Voltage Swing  
versus Load Resistance**

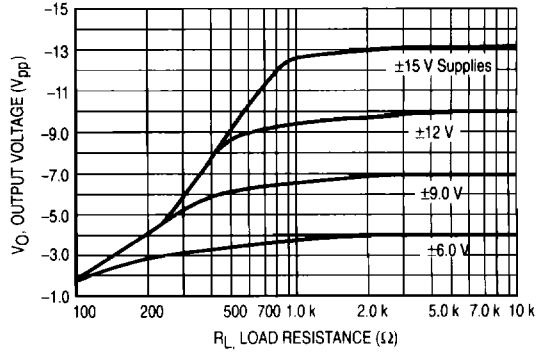

**Figure 10. Output Voltage Swing versus  
Load Resistance (Single Supply Operation)**

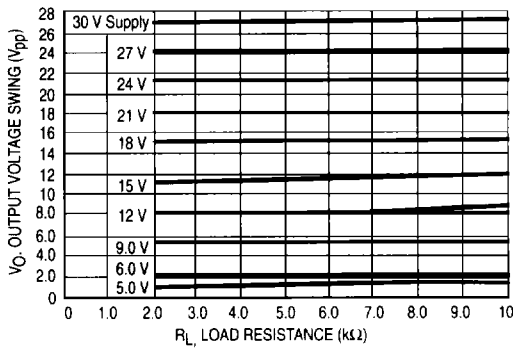

**Figure 11. Single Supply Inverting Amplifier**

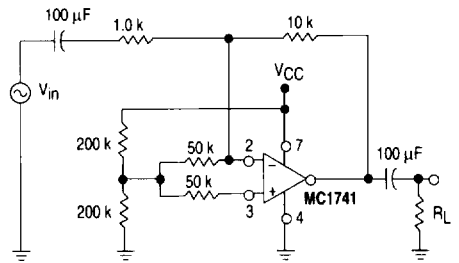

Figure 12. Noninverting Pulse Response

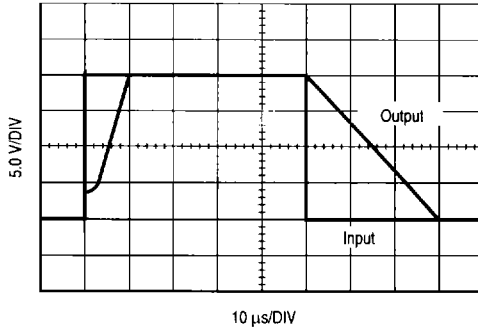

Figure 13. Transient Response Test Circuit

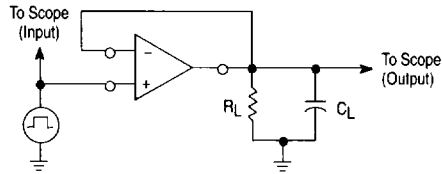

Figure 14. Open Loop Voltage Gain versus Supply Voltage

