

# MOTOROLA SEMICONDUCTOR TECHNICAL DATA

2

## Internally Compensated, High Performance Operational Amplifiers

The MC1741 and MC1741C were designed for use as summing amplifiers, integrators, or amplifiers with operating characteristics as a function of the external feedback components.

- No Frequency Compensation Required
- Short Circuit Protection
- Offset Voltage Null Capability
- Wide Common Mode and Differential Voltage Ranges
- Low Power Consumption
- No Latch Up

**MAXIMUM RATINGS** ( $T_A = +25^\circ\text{C}$ , unless otherwise noted.)

Rating	Symbol	MC1741C	MC1741	Unit
Power Supply Voltage	$V_{CC}, V_{EE}$	$\pm 18$	$\pm 22$	$V_{dc}$
Input Differential Voltage	$V_{ID}$	$\pm 30$		V
Input Common Mode Voltage (Note 1)	$V_{ICM}$	$\pm 15$		V
Output Short Circuit Duration (Note 2)	$t_{SC}$	Continuous		
Operating Ambient Temperature Range	$T_A$	0 to +70	-55 to +125	$^\circ\text{C}$
Storage Temperature Range Ceramic Package Plastic Package	$T_{stg}$	-65 to +150 -55 to +125		$^\circ\text{C}$

- NOTES:**
1. For supply voltages less than +15 V, the absolute maximum input voltage is equal to the supply voltage.
  2. Supply voltage equal to or less than 15 V.

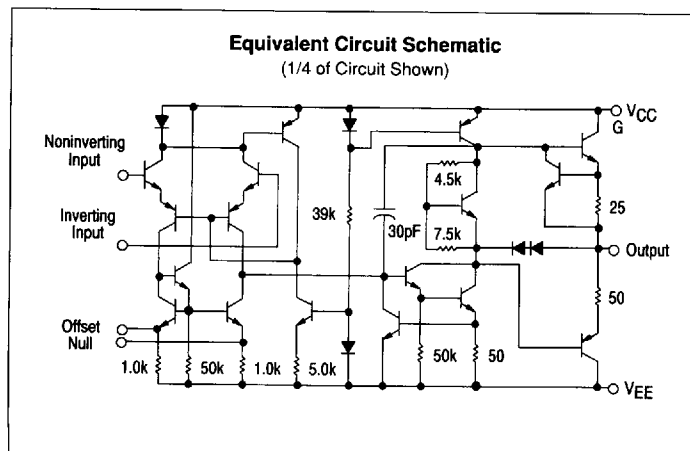

# MC1741 MC1741C

### OPERATIONAL AMPLIFIERS

SILICON MONOLITHIC  
INTEGRATED CIRCUIT



**P1 SUFFIX**  
PLASTIC PACKAGE  
CASE 626



**U SUFFIX**  
CERAMIC PACKAGE  
CASE 693



**D SUFFIX**  
PLASTIC PACKAGE  
CASE 751  
(SO-8)

### PIN CONNECTIONS

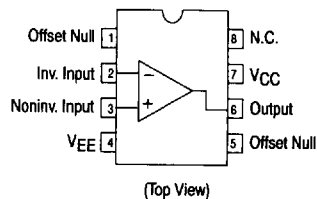

### ORDERING INFORMATION

Device	Alternate	Temperature Range	Package
MC1741CD	—	0° to +70°C	SO-8
MC1741CP1	LM741CN, μA741TC		Plastic DIP
MC1741CU	—	-55° to +125°C	Ceramic DIP
MC1741U	—		Ceramic DIP

## MC1741, MC1741C

ELECTRICAL CHARACTERISTICS ( $V_{CC} = +15\text{ V}$ ,  $V_{EE} = -15\text{ V}$ ,  $T_A = 25^\circ\text{C}$ , unless otherwise noted.)

Characteristics	Symbol	MC1741			MC1741C			Unit
		Min	Typ	Max	Min	Typ	Max	
Input Offset Voltage ( $R_S \leq 10\text{ k}$ )	$V_{IO}$	—	1.0	5.0	—	2.0	6.0	mV
Input Offset Current	$I_{IO}$	—	20	200	—	20	200	nA
Input Bias Current	$I_{IB}$	—	80	500	—	80	500	nA
Input Resistance	$r_i$	0.3	2.0	—	0.3	2.0	—	M $\Omega$
Input Capacitance	$C_i$	—	1.4	—	—	1.4	—	pF
Offset Voltage Adjustment Range	$V_{IOR}$	—	$\pm 15$	—	—	$\pm 15$	—	mV
Common Mode Input Voltage Range	$V_{ICR}$	$\pm 12$	$\pm 13$	—	$\pm 12$	$\pm 13$	—	V
Large Signal Voltage Gain ( $V_O = \pm 10\text{ V}$ , $R_L \geq 2.0\text{ k}$ )	$A_{VOL}$	50	200	—	20	200	—	V/mV
Output Resistance	$r_o$	—	75	—	—	75	—	$\Omega$
Common Mode Rejection ( $R_S \leq 10\text{ k}$ )	CMR	70	90	—	70	90	—	dB
Supply Voltage Rejection ( $R_S \leq 10\text{ k}$ )	PSR	75	—	—	75	—	—	dB
Output Voltage Swing ( $R_L \geq 10\text{ k}$ ) ( $R_L \geq 2.0\text{ k}$ )	$V_O$	$\pm 12$ $\pm 10$	$\pm 14$ $\pm 13$	—	$\pm 12$ $\pm 10$	$\pm 14$ $\pm 13$	—	V
Output Short Circuit Current	$I_{SC}$	—	20	—	—	20	—	mA
Supply Current	$I_D$	—	1.7	2.8	—	1.7	2.8	mA
Power Consumption	$P_C$	—	50	85	—	50	85	mW
Transient Response (Unity Gain, Noninverting) ( $V_i = 20\text{ mV}$ , $R_L \geq 2.0\text{ k}$ , $C_L \leq 100\text{ pF}$ ) Rise Time ( $V_i = 20\text{ mV}$ , $R_L \geq 2.0\text{ k}$ , $C_L \leq 100\text{ pF}$ ) Overshoot ( $V_i = 10\text{ V}$ , $R_L \geq 2.0\text{ k}$ , $C_L \leq 100\text{ pF}$ ) Slew Rate	$t_{LH}$ $os$ SR	—	0.3 15 0.5	—	—	0.3 15 0.5	—	$\mu\text{s}$ % V/ $\mu\text{s}$

ELECTRICAL CHARACTERISTICS ( $V_{CC} = +15\text{ V}$ ,  $V_{EE} = -15\text{ V}$ ,  $T_A = T_{low}$  to  $T_{high}$ , unless otherwise noted.)\*

Characteristics	Symbol	MC1741			MC1741C			Unit
		Min	Typ	Max	Min	Typ	Max	
Input Offset Voltage ( $R_S \leq 10\text{ k}\Omega$ )	$V_{IO}$	—	1.0	6.0	—	—	7.5	mV
Input Offset Current ( $T_A = +125^\circ\text{C}$ ) ( $T_A = -55^\circ\text{C}$ ) ( $T_A = 0^\circ$ to $+70^\circ\text{C}$ )	$I_{IO}$	—	7.0 85 —	200 500 —	—	—	— — 300	nA
Input Bias Current ( $T_A = +125^\circ\text{C}$ ) ( $T_A = -55^\circ\text{C}$ ) ( $T_A = 0^\circ$ to $+70^\circ\text{C}$ )	$I_{IB}$	—	30 300 —	500 1500 —	—	—	— — 800	nA
Common Mode Input Voltage Range	$V_{ICR}$	$\pm 12$	$\pm 13$	—	—	—	—	V
Common Mode Rejection ( $R_S \leq 10\text{ k}$ )	CMR	70	90	—	—	—	—	dB
Supply Voltage Rejection ( $R_S \leq 10\text{ k}$ )	PSR	75	—	—	75	—	—	dB
Output Voltage Swing ( $R_L \geq 10\text{ k}$ ) ( $R_L \geq 2.0\text{ k}$ )	$V_O$	$\pm 12$ $\pm 10$	$\pm 14$ $\pm 13$	—	—	$\pm 10$ $\pm 13$	—	V
Large Signal Voltage Gain ( $R_L \geq 2.0\text{ k}$ , $V_O = \pm 10\text{ V}$ )	$A_{VOL}$	25	—	—	15	—	—	V/mV
Supply Currents ( $T_A = +125^\circ\text{C}$ ) ( $T_A = -55^\circ\text{C}$ )	$I_D$	—	1.5 2.0	2.5 3.3	—	—	—	mA
Power Consumption ( $T_A = +125^\circ\text{C}$ ) ( $T_A = -55^\circ\text{C}$ )	$P_C$	—	45 60	75 100	—	—	—	mW

$T_{high} = 125^\circ\text{C}$  for MC1741  
70 $^\circ\text{C}$  for MC1741C

\*  $T_{low} = -55^\circ\text{C}$  for MC1741  
0 $^\circ\text{C}$  for MC1741C

MC1741, MC1741C

2

Figure 1. Burst Noise versus Source Resistance

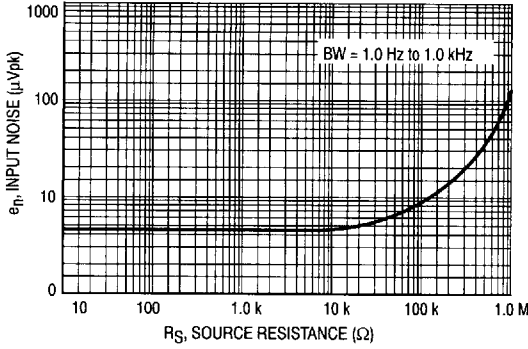

Figure 2. RMS Noise versus Source Resistance

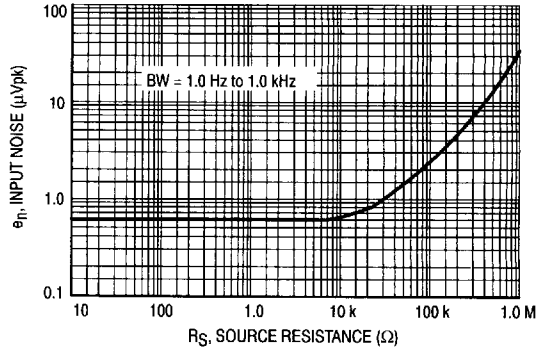

Figure 3. Output Noise versus Source Resistance

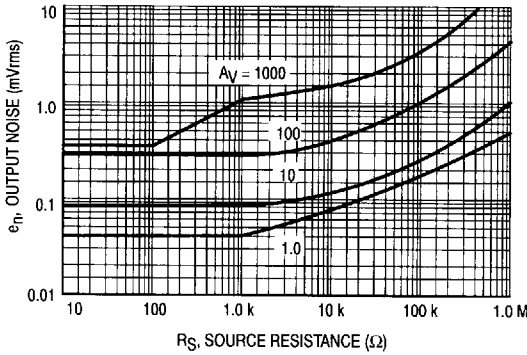

Figure 4. Spectral Noise Density

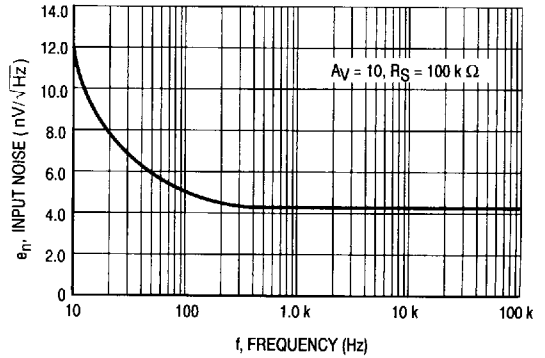
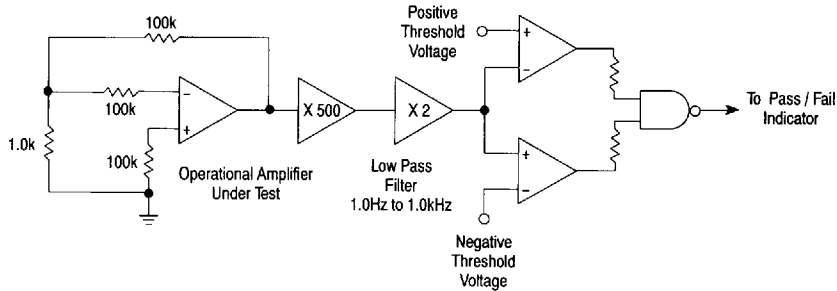

Figure 5. Burst Noise Test Circuit



Unlike conventional peak reading or RMS meters, this system was especially designed to provide the quick response time essential to burst (popcorn) noise testing.

The test time employed is 10 sec and the 20 mV peak limit refers to the operational amplifier input thus eliminating errors in the closed-loop gain factor of the operational amplifier.

MC1741, MC1741C

Figure 6. Power Bandwidth  
(Large Signal Swing versus Frequency)

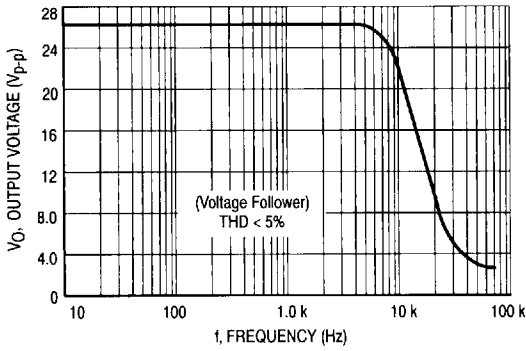

Figure 7. Open-Loop Frequency Response

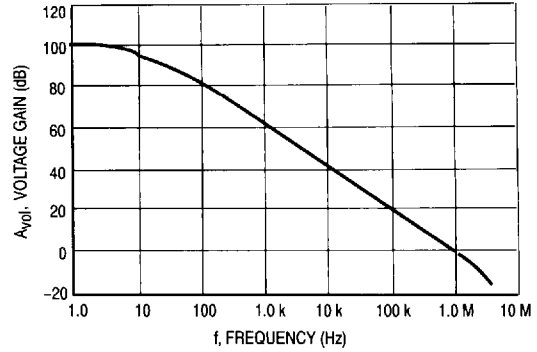

Figure 8. Positive Output Voltage Swing versus Load Resistance

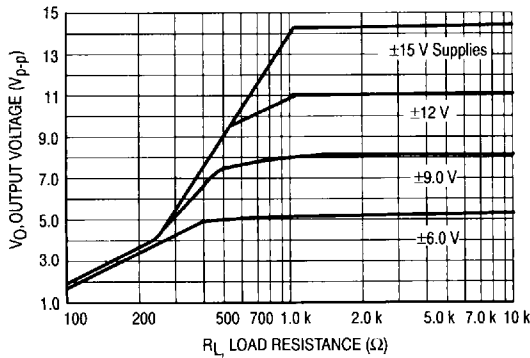

Figure 9. Negative Output Voltage Swing versus Load Resistance

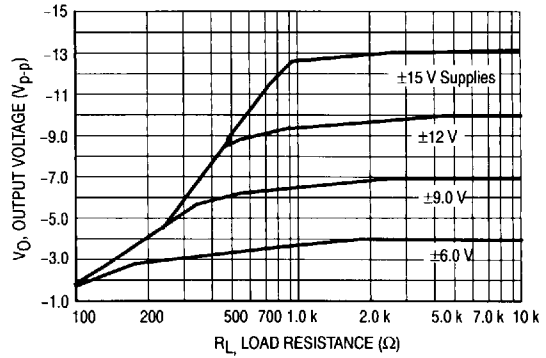

Figure 10. Output Voltage Swing versus Load Resistance (Single Supply Operation)

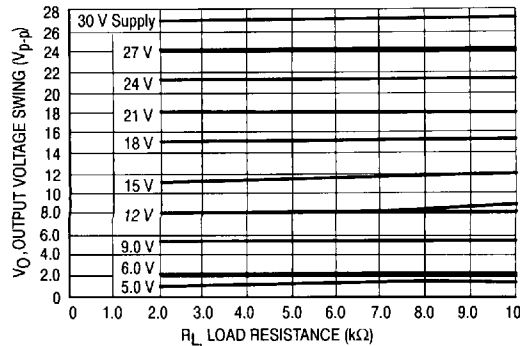
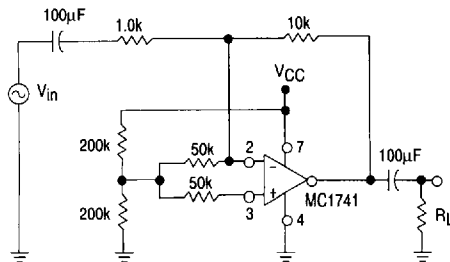
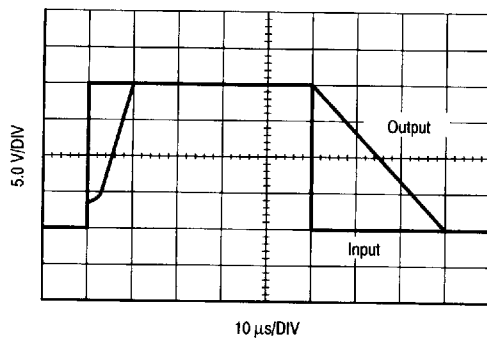
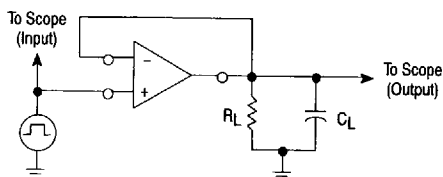

Figure 11. Single Supply Inverting Amplifier



**MC1741, MC1741C****Figure 12. Noninverting Pulse Response****Figure 13. Transient Response Test Circuit****Figure 14. Open-Loop Voltage Gain versus Supply Voltage**