



HIGH SPEED 3.3V 2K X 8 DUAL-PORT STATIC RAM WITH INTERRUPTS

IDT71V321S/L
IDT71V421S/L

Features

- ◆ **High-speed access**
 - Commercial: 25/35/55ns (max.)
 - Industrial: 25ns (max.)
- ◆ **Low-power operation**
 - IDT71V321/IDT71V421S
Active: 325mW (typ.)
Standby: 5mW (typ.)
 - IDT71V321/V421L
Active: 325mW (typ.)
Standby: 1mW (typ.)
- ◆ **Two $\overline{\text{INT}}$ flags for port-to-port communications**
- ◆ **MASTER IDT71V321 easily expands data bus width to 16-or-more-bits using SLAVE IDT71V421**
- ◆ **On-chip port arbitration logic (IDT71V321 only)**
- ◆ **BUSY output flag on IDT71V321; BUSY input on IDT71V421**
- ◆ **Fully asynchronous operation from either port**
- ◆ **Battery backup operation—2V data retention (L only)**
- ◆ **TTL-compatible, single 3.3V power supply**
- ◆ **Available in 52-pin PLCC, 64-pin TQFP and STQFP packages**
- ◆ **Industrial temperature range (-40°C to +85°C) is available for selected speeds**
- ◆ **Green parts available, see ordering information**

Functional Block Diagram

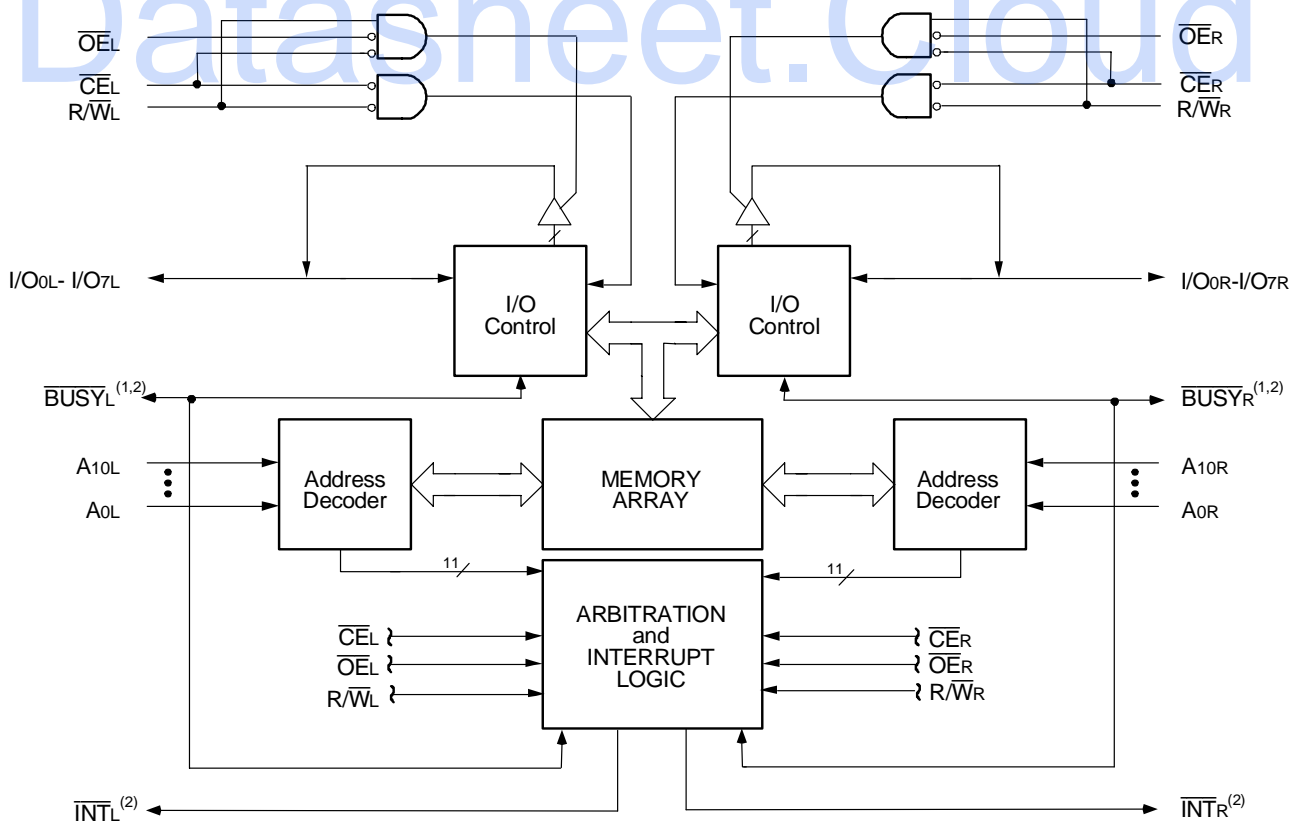

NOTES:

1. IDT71V321 (MASTER): $\overline{\text{BUSY}}$ is an output. IDT71V421 (SLAVE): $\overline{\text{BUSY}}$ is input.
2. $\overline{\text{BUSY}}$ and $\overline{\text{INT}}$ are totem-pole outputs.

OCTOBER 2008

Description

The IDT71V321/IDT71V421 are high-speed 2K x 8 Dual-Port Static RAMs with internal interrupt logic for interprocessor communications. The IDT71V321 is designed to be used as a stand-alone 8-bit Dual-Port RAM or as a "MASTER" Dual-Port RAM together with the IDT71V421 "SLAVE" Dual-Port in 16-or-more-bit memory system applications results in full speed, error-free operation without the need for additional discrete logic.

The device provides two independent ports with separate control, address, and I/O pins that permit independent, asynchronous access for reads or writes to any location in memory. An automatic power

down feature, controlled by \overline{CE} , permits the on chip circuitry of each port to enter a very low standby power mode.

Fabricated using IDT's CMOS high-performance technology, these devices typically operate on only 325mW of power. Low-power (L) versions offer battery backup data retention capability, with each Dual-Port typically consuming 200 μ W from a 2V battery.

The IDT71V321/IDT71V421 devices are packaged in a 52-pin PLCC, a 64-pin TQFP (thin quad flatpack), and a 64-pin STQFP (super thin quad flatpack).

Pin Configurations^(1,2,3)

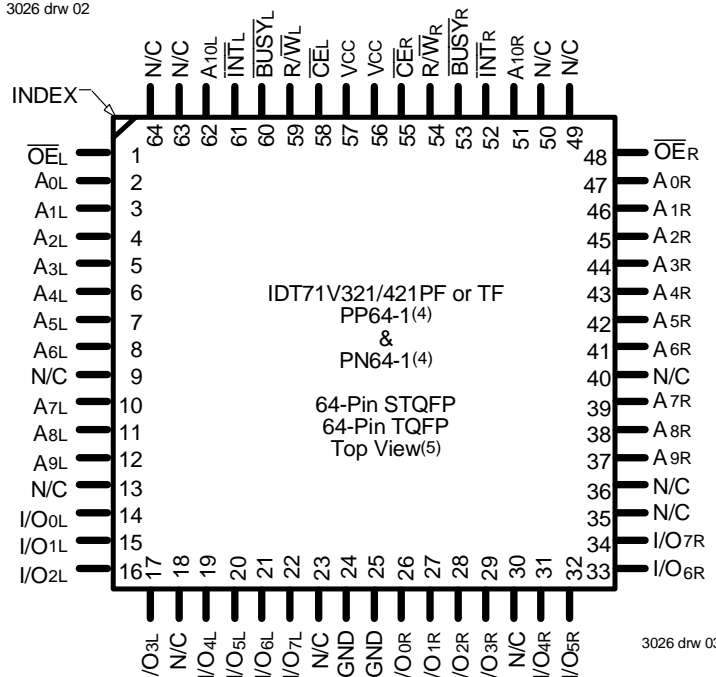
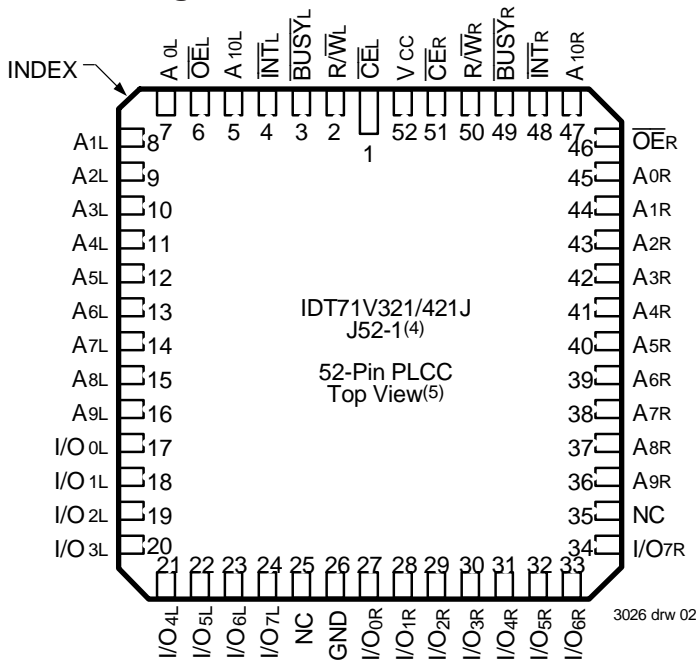

NOTES:

1. All Vcc pins must be connected to power supply.
2. All GND pins must be connected to ground supply.
3. J52-1 package body is approximately .75 in x .75 in x .17 in.
PP64-1 package body is approximately 10mm x 10mm x 1.4mm.
PN64-1 package body is approximately 14mm x 14mm x 1.4mm.
4. This package code is used to reference the package diagram.
5. This text does not indicate orientation of the actual part-marking.

Absolute Maximum Ratings⁽¹⁾

Symbol	Rating	Commercial & Industrial	Unit
V _{TERM} ⁽²⁾	Terminal Voltage with Respect to GND	-0.5 to +4.6	V
T _A	Operating Temperature	0 to +70	°C
T _{BIAS}	Temperature Under Bias	-55 to +125	°C
T _{STG}	Storage Temperature	-65 to +150	°C
I _{OUT}	DC Output Current	50	mA

3026 tbl 01

NOTES:

- Stresses greater than those listed under ABSOLUTE MAXIMUM RATINGS may cause permanent damage to the device. This is a stress rating only and functional operation of the device at these or any other conditions above those indicated in the operational sections of the specification is not implied. Exposure to absolute maximum rating conditions for extended periods may affect reliability.
- V_{TERM} must not exceed V_{CC} + 10% for more than 25% of the cycle time or 10ns maximum, and is limited to ≤ 20mA for the period of V_{TERM} ≥ V_{CC} + 10%.

Capacitance⁽¹⁾

(T_A = +25°C, f = 1.0MHz) TQFP Only

Symbol	Parameter	Conditions ⁽²⁾	Max.	Unit
C _{IN}	Input Capacitance	V _{IN} = 3dV	9	pF
C _{OUT}	Output Capacitance	V _{OUT} = 3dV	10	pF

3026 tbl 04

NOTES:

- This parameter is determined by device characterization but is not production tested.
- 3dv references the interpolated capacitance when the input and output signals switch from 0V to 3V or from 3V to 0V.

Recommended Operating Temperature and Supply Voltage^(1,2)

Grade	Ambient Temperature	GND	V _{CC}
Commercial	0°C to +70°C	0V	3.3V ± 0.3V
Industrial	-40°C to +85°C	0V	3.3V ± 0.3V

3026 tbl 02

NOTES:

- This is the parameter T_A. This is the "instant on" case temperature.
- Industrial temperature: for specific speeds, packages and powers contact your sales office.

Recommended DC Operating Conditions

Symbol	Parameter	Min.	Typ.	Max.	Unit
V _{CC}	Supply Voltage	3.0	3.3	3.6	V
GND	Ground	0	0	0	V
V _{IH}	Input High Voltage	2.0	—	V _{CC} +0.3 ⁽²⁾	V
V _{IL}	Input Low Voltage	-0.3 ⁽¹⁾	—	0.8	V

3026 tbl 03

NOTES:

- V_{IL} (min.) = -1.5V for pulse width less than 20ns.
- V_{TERM} must not exceed V_{CC} + 0.3V.

DC Electrical Characteristics Over the Operating Temperature and Supply Voltage Range (V_{CC} = 3.3V ± 0.3V)

Symbol	Parameter	Test Conditions	71V321S 71V421S		71V321L 71V421L		Unit
			Min.	Max.	Min.	Max.	
I _L	Input Leakage Current ⁽¹⁾	V _{CC} = 3.6V, V _{IN} = 0V to V _{CC}	—	10	—	5	μA
I _{LO}	Output Leakage Current	\overline{CE} = V _{IH} , V _{OUT} = 0V to V _{CC} V _{CC} = 3.6V	—	10	—	5	μA
V _{OL}	Output Low Voltage	I _{OL} = 4mA	—	0.4	—	0.4	V
V _{OH}	Output High Voltage	I _{OH} = -4mA	2.4	—	2.4	—	V

3026 tbl 05

NOTE:

- At V_{CC} ≤ 2.0V input leakages are undefined.

DC Electrical Characteristics Over the Operating Temperature and Supply Voltage Range^(1,2) (V_{CC} = 3.3V ± 0.3V)

Symbol	Parameter	Test Condition	Version	71V321X25 71V421X25 Com'l & Ind		71V321X35 71V421X35 Com'l Only		71V321X55 71V421X55 Com'l Only		Unit	
				Typ.	Max.	Typ.	Max.	Typ.	Max.		
I _{CC}	Dynamic Operating Current (Both Ports Active)	$\overline{CE} = V_{IL}$, Outputs Disabled $SE_M = V_{IH}$ $f = f_{MAX}^{(3)}$	COM'L	S	55	130	55	125	55	115	mA
				L	55	100	55	95	55	85	
			IND	S	55	150	—	—	—	—	
				L	55	130	—	—	—	—	
I _{SB1}	Standby Current (Both Ports - TTL Level Inputs)	$\overline{CE}_R = \overline{CE}_L = V_{IH}$ $SE_{MR} = SE_{ML} = V_{IH}$ $f = f_{MAX}^{(3)}$	COM'L	S	15	35	15	35	15	35	mA
				L	15	20	15	20	15	20	
			IND	S	15	50	—	—	—	—	
				L	15	35	—	—	—	—	
I _{SB2}	Standby Current (One Port - TTL Level Inputs)	$\overline{CE}_{A^*} = V_{IL}$ and $\overline{CE}_{B^*} = V_{IH}^{(6)}$ Active Port Outputs Disabled, $f = f_{MAX}^{(3)}$ $SE_{MR} = SE_{ML} = V_{IH}$	COM'L	S	25	75	25	70	25	60	mA
				L	25	55	25	50	25	40	
			IND	S	25	95	—	—	—	—	
				L	25	75	—	—	—	—	
I _{SB3}	Full Standby Current (Both Ports - All CMOS Level Inputs)	Both Ports \overline{CE}_L and $\overline{CE}_R \geq V_{CC} - 0.2V$ $V_{IN} \geq V_{CC} - 0.2V$ or $V_{IN} < 0.2V$, $f = 0^{(4)}$ $SE_{MR} = SE_{ML} \geq V_{CC} - 0.2V$	COM'L	S	1.0	5	1.0	5	1.0	5	mA
				L	0.2	3	0.2	3	0.2	3	
			IND	S	1.0	10	—	—	—	—	
				L	0.2	6	—	—	—	—	
I _{SB4}	Full Standby Current (One Port - All CMOS Level Inputs)	$\overline{CE}_{A^*} \leq 0.2V$ and $\overline{CE}_{B^*} \geq V_{CC} - 0.2V^{(6)}$ $SE_{MR} = SE_{ML} \geq V_{CC} - 0.2V$ $V_{IN} \geq V_{CC} - 0.2V$ or $V_{IN} \leq 0.2V$ Active Port Outputs Disabled $f = f_{MAX}^{(3)}$	COM'L	S	25	70	25	65	25	55	mA
				L	25	55	25	50	25	40	
			IND	S	25	85	—	—	—	—	
				L	25	70	—	—	—	—	

3026 tbl 06

NOTES:

- 'X' in part numbers indicates power rating (S or L).
- V_{CC} = 3.3V, T_A = +25°C, and are not production tested. I_{CCDC} = 70mA (Typ).
- At f = f_{MAX}, address and control lines (except Output Enable) are cycling at the maximum frequency read cycle of 1/trc and using "AC Test Conditions" of input levels of GND to 3V.
- f = 0 means no address or control lines change. Applies only to inputs at CMOS level standby.
- Port "A" may be either left or right port. Port "B" is opposite from port "A".

Data Retention Characteristics (L Version Only)

Symbol	Parameter	Test Condition	Min.	Typ. ⁽¹⁾	Max.	Unit	
V _{DR}	V _{CC} for Data Retention		2.0	—	0	V	
I _{CCDR}	Data Retention Current	V _{CC} = 2V, $\overline{CE} \geq V_{CC} - 0.2V$	COM'L.	—	100	1500	μA
t _{CDR} ⁽³⁾	Chip Deselect to Data Retention Time	V _{IN} ≥ V _{CC} - 0.2V or V _{IN} ≤ 0.2V	IND.	—	100	4000	μA
				0	—	—	V
t _R ⁽³⁾	Operation Recovery Time		t _{RC} ⁽²⁾	—	—	—	V

3026 tbl 07

NOTES:

- V_{CC} = 2V, T_A = +25°C, and is not production tested.
- t_{RC} = Read Cycle Time.
- This parameter is guaranteed by device characterization but not production tested.

AC Test Conditions

Input Pulse Levels	GND to 3.0V
Input Rise/Fall Times	5ns
Input Timing Reference Levels	1.5V
Output Reference Levels	1.5V
Output Load	Figures 1 and 2

3026 tbl 08

Data Retention Waveform

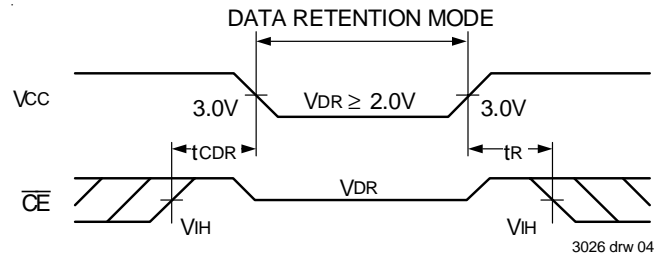

3026 drw 04

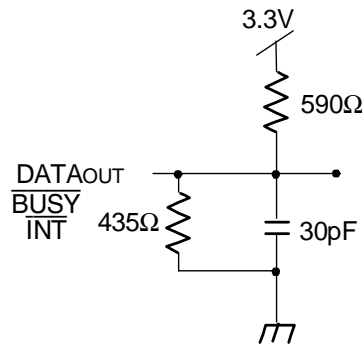
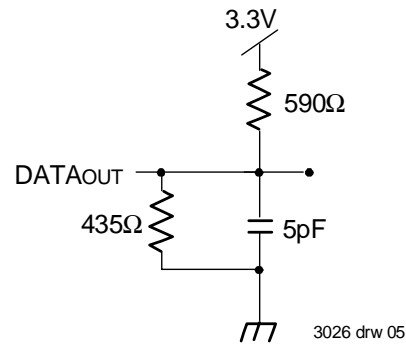

Figure 1. AC Output Test Load



3026 drw 05

Figure 2. Output Test Load
(for tHZ, tLZ, tWZ, and tOW)
* Including scope and jig.

AC Electrical Characteristics Over the Operating Temperature Supply Voltage Range⁽²⁾

Symbol	Parameter	71V321X25 71V421X25 Com'l & Ind		71V321X35 71V421X35 Com'l Only		71V321X55 71V421X55 Com'l Only		Unit
		Min.	Max.	Min.	Max.	Min.	Max.	
READ CYCLE								
t _{RC}	Read Cycle Time	25	—	35	—	55	—	ns
t _{AA}	Address Access Time	—	25	—	35	—	55	ns
t _{ACE}	Chip Enable Access Time	—	25	—	35	—	55	ns
t _{AOE}	Output Enable Access Time	—	12	—	20	—	25	ns
t _{OH}	Output Hold from Address Change	3	—	3	—	3	—	ns
t _{LZ}	Output Low-Z Time ^(1,2)	0	—	0	—	0	—	ns
t _{HZ}	Output High-Z Time ^(1,2)	—	12	—	15	—	30	ns
t _{PU}	Chip Enable to Power Up Time ⁽²⁾	0	—	0	—	0	—	ns
t _{PD}	Chip Disable to Power Down Time ⁽²⁾	—	50	—	50	—	50	ns

3026 tbl 09

NOTES:

1. Transition is measured 0mV from Low or High-impedance voltage with Output Test Load (Figure 2).
2. This parameter is guaranteed by device characterization, but is not production tested.
3. 'X' in part numbers indicates power rating (S or L).

Timing Waveform of Read Cycle No. 1, Either Side⁽¹⁾

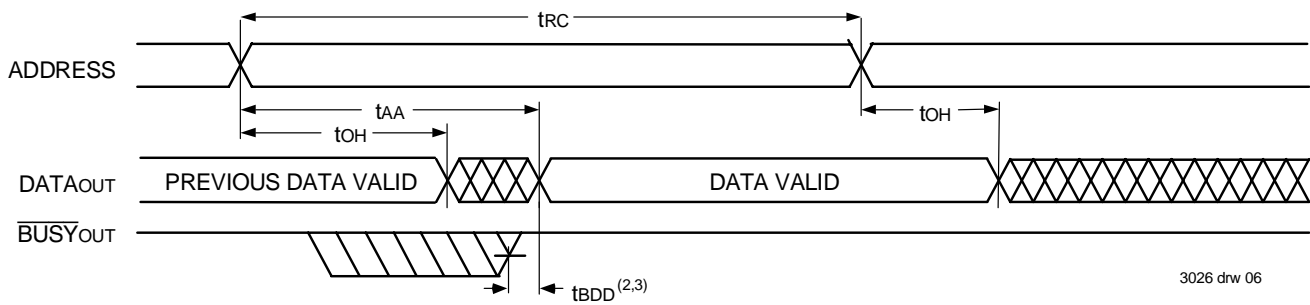

NOTES:

1. $R\bar{W} = V_{IH}$, $\bar{CE} = V_{IL}$, and is $\bar{OE} = V_{IL}$. Address is valid prior to the coincidental with \bar{CE} transition LOW.
2. t_{BDD} delay is required only in the case where the opposite port is completing a write operation to the same address location. For simultaneous read operations $BUSY$ has no relationship to valid output data.
3. Start of valid data depends on which timing becomes effective last t_{AOE} , t_{ACE} , t_{AA} , and t_{BDD} .

Timing Waveform of Read Cycle No. 2, Either Side⁽³⁾

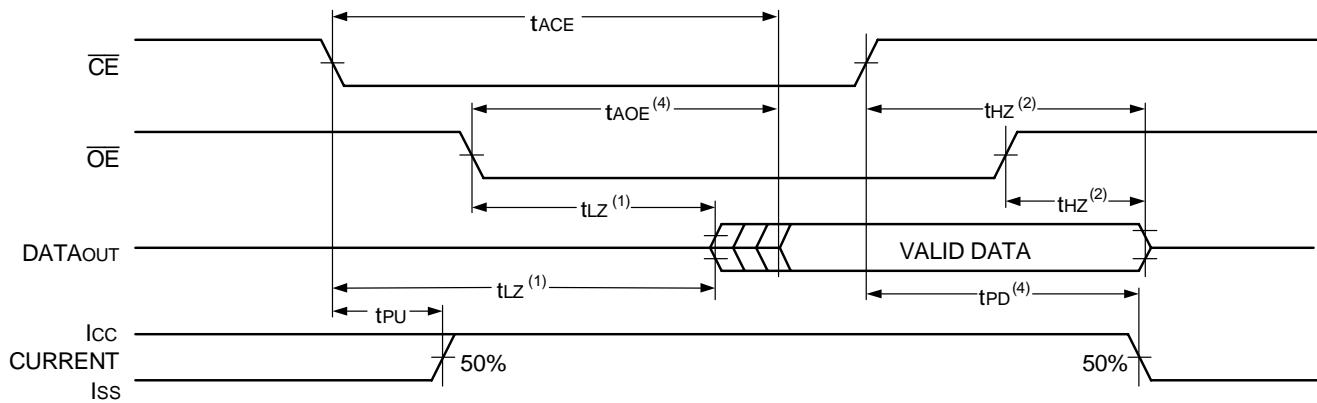

NOTES:

1. Timing depends on which signal is asserted last, \bar{OE} or \bar{CE} .
2. Timing depends on which signal is de-asserted first, \bar{OE} or \bar{CE} .
3. $R\bar{W} = V_{IH}$ and the address is valid prior to or coincidental with \bar{CE} transition LOW.
4. Start of valid data depends on which timing becomes effective last t_{AOE} , t_{ACE} , t_{AA} , and t_{BDD} .

AC Electrical Characteristics Over the Operating Temperature and Supply Voltage Range⁽⁴⁾

Symbol	Parameter	71V321X25 71V421X25 Com'l & Ind		71V321X35 71V421X35 Com'l Only		71V321X55 71V421X55 Com'l Only		Unit
		Min.	Max.	Min.	Max.	Min.	Max.	
WRITE CYCLE								
t _{wc}	Write Cycle Time ⁽⁵⁾	25	—	35	—	55	—	ns
t _{ew}	Chip Enable to End-of-Write	20	—	30	—	40	—	ns
t _{aw}	Address Valid to End-of-Write	20	—	30	—	40	—	ns
t _{as}	Address Set-up Time	0	—	0	—	0	—	ns
t _{wp}	Write Pulse Width	20	—	30	—	40	—	ns
t _{wr}	Write Recovery Time	0	—	0	—	0	—	ns
t _{dw}	Data Valid to End-of-Write	12	—	20	—	20	—	ns
t _{hz}	Output High-Z Time ^(1,2)	—	12	—	15	—	30	ns
t _{dh}	Data Hold Time ⁽³⁾	0	—	0	—	0	—	ns
t _{wz}	Write Enable to Output in High-Z ^(1,2)	—	15	—	15	—	30	ns
t _{ow}	Output Active from End-of-Write ^(1,2)	0	—	0	—	0	—	ns

3026 tbl 10

NOTES:

1. Transition is measured 0mV from Low or High-impedance voltage with Output Test Load (Figure 2).
2. This parameter is guaranteed by device characterization but is not production tested.
3. The specification for t_{dh} must be met by the device supplying write data to the RAM under all operating conditions. Although t_{dh} and t_{ow} values will vary over voltage and temperature, the actual t_{dh} will always be smaller than the actual t_{ow}.
4. 'X' in part numbers indicates power rating (S or L).
5. For Master/Slave combination, t_{wc} = t_{BAA} + t_{wp}, since R \overline{W} = V_{IL} must occur after t_{BAA}.

Timing Waveform of Write Cycle No. 1, (R/\overline{W} Controlled Timing)^(1,5,8)

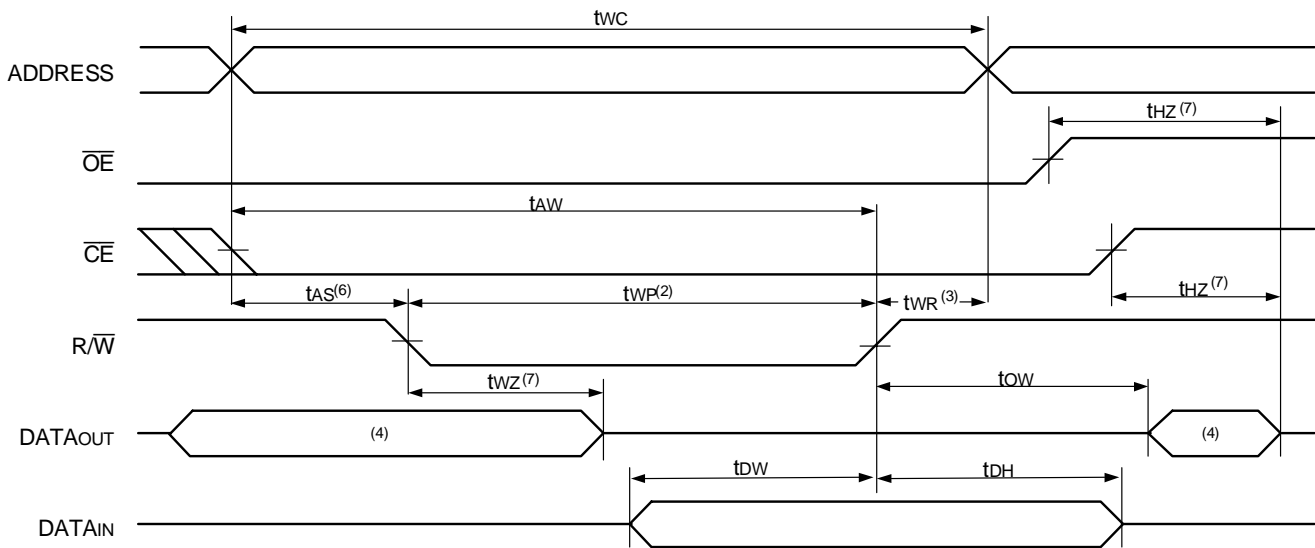

3026 drw 08

Timing Waveform of Write Cycle No. 2, (\overline{CE} Controlled Timing)^(1,5)

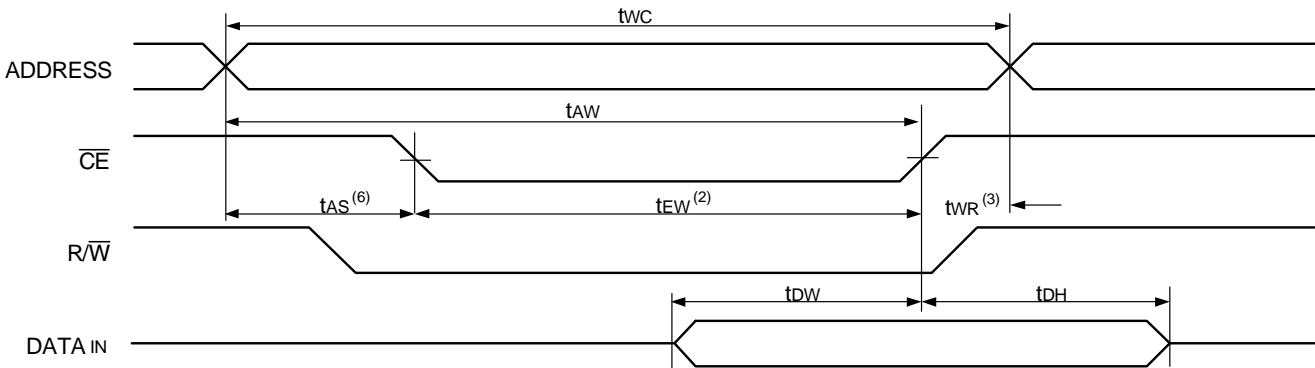

3026 drw 09

NOTES:

1. R/\overline{W} or \overline{CE} must be HIGH during all address transitions.
2. A write occurs during the overlap (t_{EW} or t_{WP}) of $\overline{CE} = V_{IL}$ and $R/\overline{W} = V_{IL}$.
3. t_{WR} is measured from the earlier of \overline{CE} or R/\overline{W} going HIGH to the end of the write cycle.
4. During this period, the I/O pins are in the output state and input signals must not be applied.
5. If the \overline{CE} LOW transition occurs simultaneously with or after the R/\overline{W} LOW transition, the outputs remain in the High-impedance state.
6. Timing depends on which enable signal (\overline{CE} or R/\overline{W}) is asserted last.
7. This parameter is determined to be device characterization, but is not production tested. Transition is measured 0mV from steady state with the Output Test Load (Figure 2).
8. If \overline{OE} is LOW during a R/\overline{W} controlled write cycle, the write pulse width must be the larger of t_{WP} or $(t_{WZ} + t_{OW})$ to allow the I/O drivers to turn off data to be placed on the bus for the required t_{OW} . If \overline{OE} is HIGH during a R/\overline{W} controlled write cycle, this requirement does not apply and the write pulse can be as short as the specified t_{WP} .

AC Electrical Characteristics Over the Operating Temperature and Supply Voltage Range⁽⁶⁾

Symbol	Parameter	71V321X25 71V421X25 Com'1 & Ind		71V321X35 71V421X35 Com'1 Only		71V321X55 71V421X55 Com'1 Only		Unit
		Min.	Max.	Min.	Max.	Min.	Max.	
BUSY Timing (For Master IDT71V321 Only)								
t _{BAA}	$\overline{\text{BUSY}}$ Access Time from Address	—	20	—	20	—	30	ns
t _{BDA}	$\overline{\text{BUSY}}$ Disable Time from Address	—	20	—	20	—	30	ns
t _{BAC}	$\overline{\text{BUSY}}$ Access Time from Chip Enable	—	20	—	20	—	30	ns
t _{BDC}	$\overline{\text{BUSY}}$ Disable Time from Chip Enable	—	20	—	20	—	30	ns
t _{WH}	Write Hold After $\overline{\text{BUSY}}^{(6)}$	12	—	15	—	20	—	ns
t _{WDD}	Write Pulse to Data Delay ⁽¹⁾	—	50	—	60	—	80	ns
t _{DDD}	Write Data Valid to Read Data Delay ⁽¹⁾	—	35	—	45	—	65	ns
t _{APS}	Arbitration Priority Set-up Time ⁽²⁾	5	—	5	—	5	—	ns
t _{BDD}	BUSY Disable to Valid Data ⁽³⁾	—	30	—	30	—	45	ns
BUSY Timing (For Slave IDT71V421 Only)								
t _{WB}	$\overline{\text{BUSY}}$ Input to Write ⁽⁴⁾	0	—	0	—	0	—	ns
t _{WH}	Write Hold After $\overline{\text{BUSY}}^{(6)}$	12	—	15	—	20	—	ns
t _{WDD}	Write Pulse to Data Delay ⁽¹⁾	—	50	—	60	—	80	ns
t _{DDD}	Write Data Valid to Read Data Delay ⁽¹⁾	—	35	—	45	—	65	ns

3026 tbl 11

NOTES:

1. Port-to-port delay through RAM cells from the writing port to the reading port, refer to "Timing Waveform of Write with Port-to-Port Read and $\overline{\text{BUSY}}$."
2. To ensure that the earlier of the two ports wins.
3. t_{BDD} is a calculated parameter and is the greater of 0, t_{WDD} - t_{WP} (actual) or t_{DDD} - t_{DW} (actual).
4. To ensure that a write cycle is inhibited on port "B" during contention on port "A".
5. To ensure that a write cycle is completed on port "B" after contention on port "A".
6. 'X' in part numbers indicates power rating (S or L).

Timing Waveform of Write with Port-to-Port Read and $\overline{\text{BUSY}}^{(2,3,4)}$

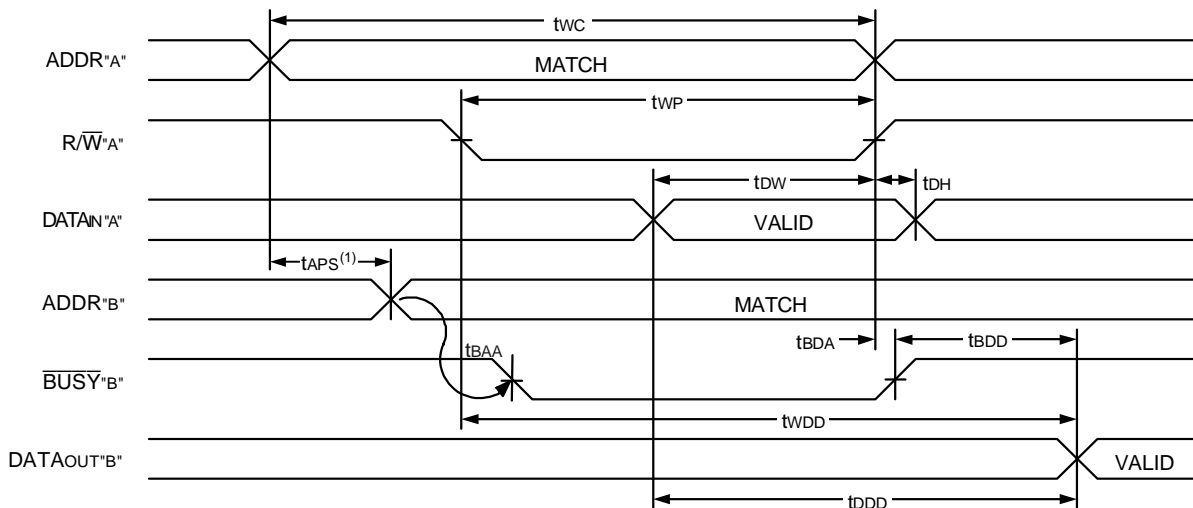

NOTES:

1. To ensure that the earlier of the two ports wins. t_{APS} is ignored for SLAVE (71V421).
2. $\overline{\text{CE}}_L = \overline{\text{CE}}_R = V_{IL}$
3. $\overline{\text{OE}} = V_{IL}$ for the reading port.
4. All timing is the same for the left and right ports. Port "A" may be either the left or right port. Port "B" is opposite from port "A".

3026 drw 10

Timing Waveform of Write with **BUSY**⁽⁴⁾

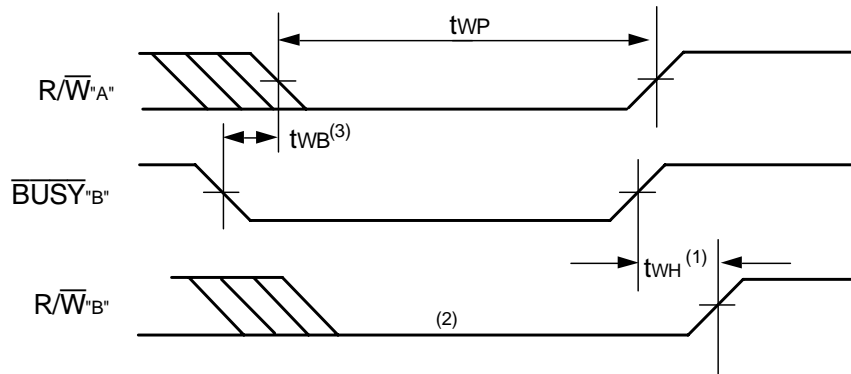

3026 drw 11

NOTES:

1. t_{WH} must be met for both \overline{BUSY} input (71V421, slave) or output (71V321, master).
2. \overline{BUSY} is asserted on port 'B' blocking R/\overline{W}'_B , until \overline{BUSY}'_B goes HIGH.
3. t_{WB} is for the slave version (71V421).
4. All timing is the same for the left and right ports. Port "A" may be either the left or right port. Port "B" is oppsite from port "A".

Timing Waveform of **BUSY** Arbitration Controlled by \overline{CE} Timing⁽¹⁾

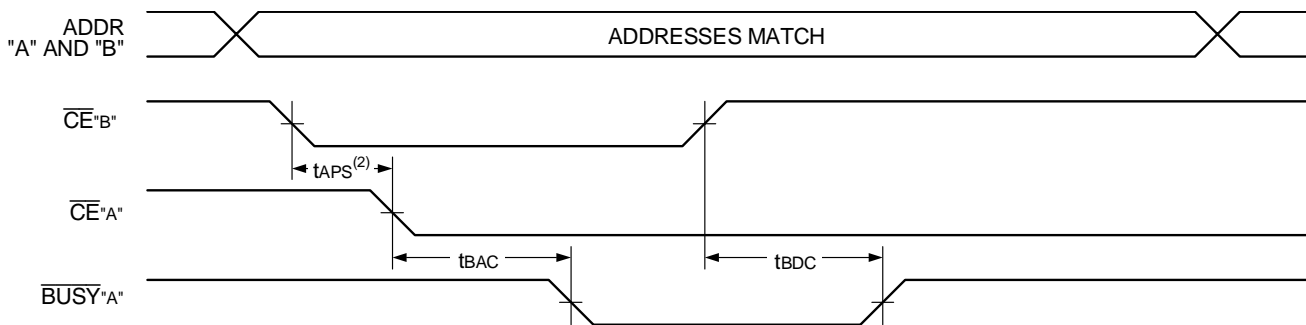

3026 drw 12

Timing Waveform of **BUSY** Arbritration Controlled by Address Match Timing⁽¹⁾

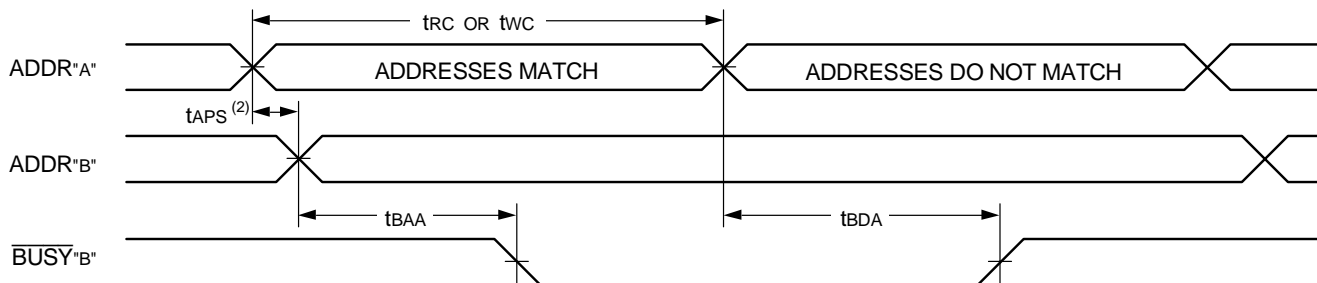

3026 drw 13

NOTES:

1. All timing is the same for left and right ports. Port "A" may be either left or right port. Port "B" is the opposite from port "A".
2. If t_{APS} is not satisfied, the \overline{BUSY} will be asserted on one side or the other, but there is no guarantee on which side \overline{BUSY} will be asserted (71V321 only).

AC Electrical Characteristics Over the Operating Temperature and Supply Voltage Range⁽¹⁾

Symbol	Parameter	71V321X25 71V421X25 Com'l & Ind		71V321X35 71V421X35 Com'l Only		71V321X55 71V421X55 Com'l Only		Unit
		Min.	Max.	Min.	Max.	Min.	Max.	
INTERRUPT TIMING								
t _{AS}	Address Set-up Time	0	—	0	—	0	—	ns
t _{WR}	Write Recovery Time	0	—	0	—	0	—	ns
t _{INS}	Interrupt Set Time	—	25	—	25	—	45	ns
t _{INR}	Interrupt Reset Time	—	25	—	25	—	45	ns

3026 tbl 12

NOTES:

1. 'X' in part numbers indicates power rating (S or L).

Timing Waveform of Interrupt Mode⁽¹⁾

SET $\overline{\text{INT}}$

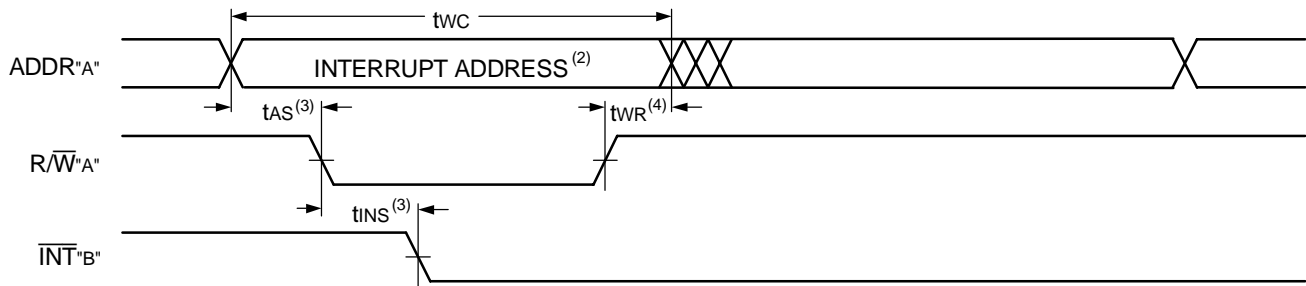

3026 drw 14

CLEAR $\overline{\text{INT}}$

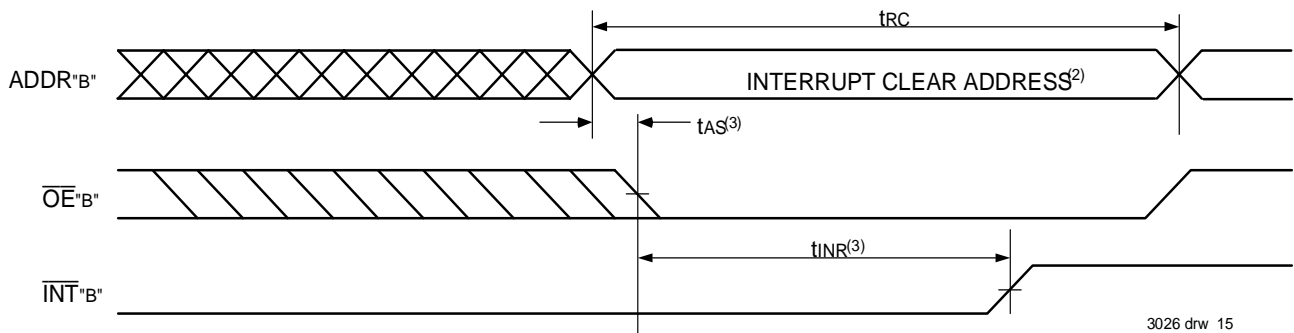

3026 drw 15

NOTES:

- All timing is the same for left and right ports. Port "A" may be either left or right port. Port "B" is the opposite from port "A".
- See Interrupt Truth Table.
- Timing depends on which enable signal ($\overline{\text{CE}}$ or $\text{R}/\overline{\text{W}}$) is asserted last.
- Timing depends on which enable signal (CE or $\text{R}/\overline{\text{W}}$) is de-asserted first.

Truth Tables

Table I. Non-Contention Read/Write Control⁽⁴⁾

Left or Right Port ⁽¹⁾				Function
R/W	\overline{CE}	\overline{OE}	Do-7	
X	H	X	Z	Port Deselected and in Power-Down Mode. ISB2 or ISB4
X	H	X	Z	$\overline{CE}_R = \overline{CE}_L = V_{IH}$, Power-Down Mode ISB1 or ISB3
L	L	X	DATAIN	Data on Port Written Into Memory ⁽²⁾
H	L	L	DATAOUT	Data in Memory Output on Port ⁽³⁾
H	L	H	Z	High-impedance Outputs

3026 tbl 13

NOTES:

1. $A_{0L} - A_{10L} \neq A_{0R} - A_{10R}$.
2. If $\overline{BUSY} = L$, data is not written.
3. If $\overline{BUSY} = L$, data may not be valid, see t_{WDD} and t_{DD} timing.
4. 'H' = V_{IH} , 'L' = V_{IL} , 'X' = DON'T CARE, 'Z' = High-impedance.

Table II. Interrupt Flag^(1,4)

Left Port					Right Port					Function
R/WL	\overline{CE}_L	\overline{OE}_L	A10L-A0L	\overline{INT}_L	R/Wr	\overline{CE}_R	\overline{OE}_R	A10R-A0R	\overline{INT}_R	
L	L	X	7FF	X	X	X	X	X	L ⁽²⁾	Set Right \overline{INT}_R Flag
X	X	X	X	X	X	L	L	7FF	H ⁽³⁾	Reset Right \overline{INT}_R Flag
X	X	X	X	L ⁽³⁾	L	L	X	7FE	X	Set Left \overline{INT}_L Flag
X	L	L	7FE	H ⁽²⁾	X	X	X	X	X	Reset Left \overline{INT}_L Flag

3026 tbl 14

NOTES:

1. Assumes $\overline{BUSY}_L = \overline{BUSY}_R = V_{IH}$
2. If $\overline{BUSY}_L = V_{IL}$, then No Change.
3. If $\overline{BUSY}_R = V_{IL}$, then No Change.
4. 'H' = HIGH, 'L' = LOW, 'X' = DON'T CARE

Table III — Address **BUSY** Arbitration

Inputs			Outputs		Function
\overline{CE}_L	\overline{CE}_R	A0L-A10L A0R-A10R	\overline{BUSY}_L ⁽¹⁾	\overline{BUSY}_R ⁽¹⁾	
X	X	NO MATCH	H	H	Normal
H	X	MATCH	H	H	Normal
X	H	MATCH	H	H	Normal
L	L	MATCH	(2)	(2)	Write Inhibit ⁽³⁾

3026 tbl 15

NOTES:

1. Pins \overline{BUSY}_L and \overline{BUSY}_R are both outputs for IDT71V321 (master). Both are inputs for IDT71V421 (slave). \overline{BUSY}_x outputs on the IDT71V321 are totem-pole. On slaves the \overline{BUSY}_x input internally inhibits writes.
2. 'L' if the inputs to the opposite port were stable prior to the address and enable inputs of this port. 'H' if the inputs to the opposite port became stable after the address and enable inputs of this port. If t_{APS} is not met, either \overline{BUSY}_L or $\overline{BUSY}_R = LOW$ will result. \overline{BUSY}_L and \overline{BUSY}_R outputs can not be LOW simultaneously.
3. Writes to the left port are internally ignored when \overline{BUSY}_L outputs are driving LOW regardless of actual logic level on the pin. Writes to the right port are internally ignored when \overline{BUSY}_R outputs are driving LOW regardless of actual logic level on the pin.

Functional Description

The IDT71V321/IDT71V421 provides two ports with separate control, address and I/O pins that permit independent access for reads or writes to any location in memory. The IDT71V321/IDT71V421 has an automatic power down feature controlled by \overline{CE} . The \overline{CE} controls on-chip power down circuitry that permits the respective port to go into a standby mode when not selected ($\overline{CE} = V_{IH}$). When a port is enabled, access to the entire memory array is permitted.

Interrupts

If the user chooses the interrupt function, a memory location (mail box or message center) is assigned to each port. The left port interrupt flag (\overline{INT}_L) is asserted when the right port writes to memory location 7FE (HEX), where a write is defined as the $\overline{CE}_R = R/\overline{W}_R = V_{IL}$ per Truth Table II. The left port clears the interrupt by accessing address location 7FE when $\overline{CE}_L = \overline{OE}_L = V_{IL}$, R/W is a "don't care". Likewise, the right port interrupt flag (\overline{INT}_R) is asserted when the left port writes to memory location 7FF (HEX) and to clear the interrupt flag (\overline{INT}_R), the right port must access the memory location 7FF. The message (8 bits) at 7FE or 7FF is user-defined, since it is an addressable SRAM location. If the interrupt function is not used, address locations 7FE and 7FF are not used as mail boxes, but as part of the random access memory. Refer to Truth Table II for the interrupt operation.

Busy Logic

Busy Logic provides a hardware indication that both ports of the RAM have accessed the same location at the same time. It also allows one of the two accesses to proceed and signals the other side that the RAM is "Busy". The \overline{BUSY} pin can then be used to stall the access until the operation on the other side is completed. If a write operation has been attempted from the side that receives a busy indication, the write signal is gated internally to prevent the write from proceeding.

The use of \overline{BUSY} Logic is not required or desirable for all applications. In some cases it may be useful to logically OR the \overline{BUSY} outputs together and use any \overline{BUSY} indication as an interrupt source to flag the event of an illegal or illogical operation.

The \overline{BUSY} outputs on the IDT71V321 RAM master are totem-pole type outputs and do not require pull-up resistors to operate. If these RAMs are

being expanded in depth, then the \overline{BUSY} indication for the resulting array requires the use of an external AND gate.

Width Expansion with Busy Logic Master/Slave Arrays

When expanding an SRAM array in width while using \overline{BUSY} logic, one master part is used to decide which side of the SRAM array will receive a \overline{BUSY} indication. Any number of slaves to be addressed in the same address range as the master, use the \overline{BUSY} signal as a write inhibit signal. Thus on the IDT71V321/IDT71V421 SRAMs the \overline{BUSY} pin is an output if the part is Master (IDT71V321), and the \overline{BUSY} pin is an input if the part is a Slave (IDT71V421) as shown in Figure 3.

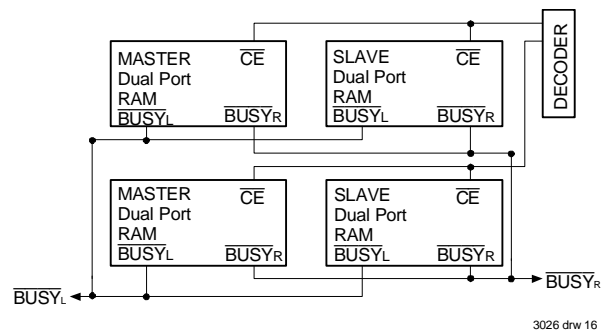

3026 drw 16
Figure 3. Busy and chip enable routing for both width and depth expansion with IDT71V321 (Master) and (Slave) IDT71V421 RAMs.

If two or more master parts were used when expanding in width, a split decision could result with one master indicating \overline{BUSY} on one side of the array and another master indicating \overline{BUSY} on one other side of the array. This would inhibit the write operations from one port for part of a word and inhibit the write operations from the other port for the other part of the word.

The \overline{BUSY} arbitration, on a Master, is based on the chip enable and address signals only. It ignores whether an access is a read or write. In a master/slave array, both address and chip enable must be valid long enough for a \overline{BUSY} flag to be output from the master before the actual write pulse can be initiated with either the R/\overline{W} signal or the byte enables. Failure to observe this timing can result in a glitched internal write inhibit signal and corrupted data in the slave.

Ordering Information

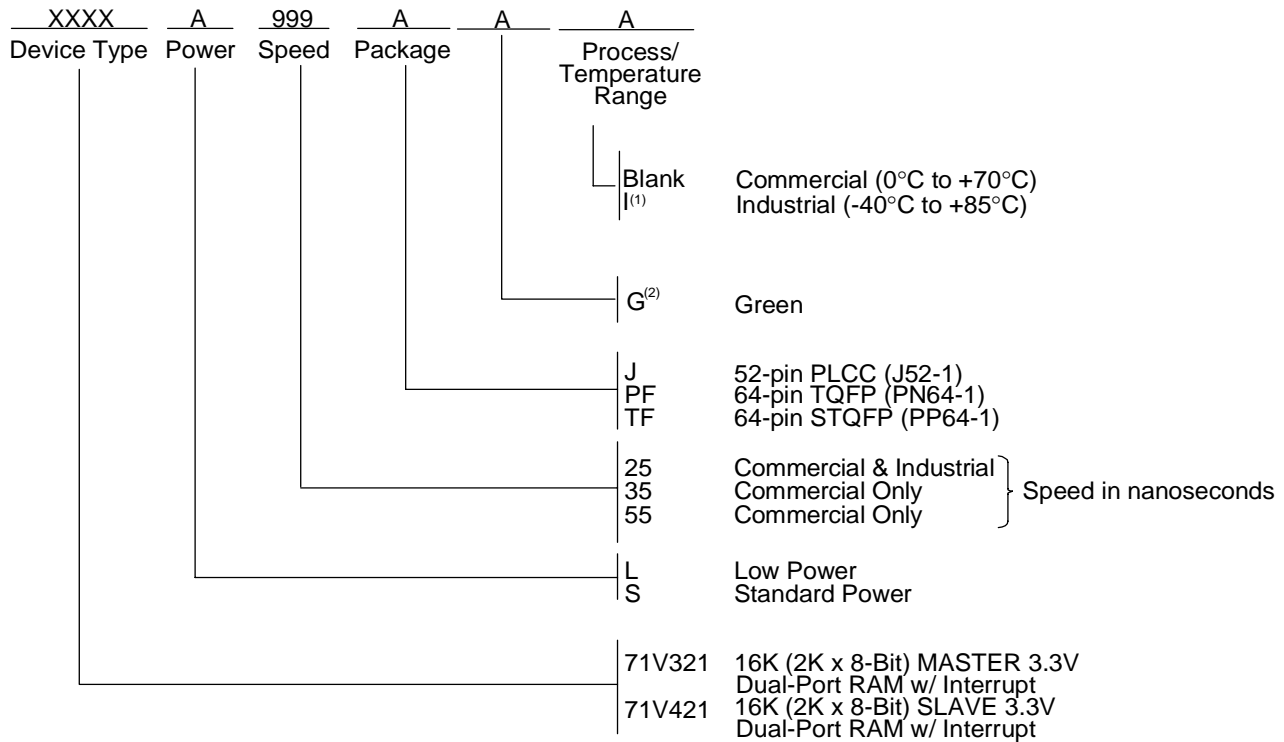

3026 drw 17

NOTES:

- Contact your sales office Industrial temperature range is available for selected speeds, packages and powers.
- Green parts available. For specific speeds, packages and powers contact your local sales office.

Datasheet Document History

03/24/99:		Initiated datasheet document history Converted to new format Cosmetic and typographical corrections
06/15/99:	Page 2	Added additional notes to pin configurations Changed drawing format
10/15/99:	Page 12	Changed open drain to totem-pole in Table III, note 1
10/21/99:	Page 13	Deleted 'does not' in copy from Busy Logic
11/12/99:		Replaced IDT logo
01/12/01:	Pages 1 & 2 Page 3	Moved full "Description" to page 2 and adjusted page layouts Increased storage temperature parameters Clarified TA parameter
	Page 4	DC Electrical parameters—changed wording from "open" to "disabled" Changed ±200mV to 0mV in notes
08/22/01:	Pages 4, 5, 7, 9 & 11	Industrial temp range offering removed from DC & AC Electrical Characteristics for 35 and 55ns
01/17/06:	Page 1 Page 14 Page 1 & 14	Added green availability to features Added green indicator to ordering information Replaced old IDT™ with new IDT™ logo

Datasheet document history continued on page 15

Datasheet Document History (con't)

08/25/06: Page 11 Changed $\overline{\text{INT}}\text{"A"}$ to $\overline{\text{INT}}\text{"B"}$ in the CLEAR $\overline{\text{INT}}$ drawing in the Timing Waveform of Interrupt Mode
10/23/08: Page 14 Removed "IDT" from orderable part number



CORPORATE HEADQUARTERS
6024 Silver Creek Valley Road
San Jose, CA 95138

for SALES:
800-345-7015 or 408-284-8200
fax: 408-284-2775
www.idt.com

for Tech Support:
408-284-2794
DualPortHelp@idt.com

The IDT logo is a registered trademark of Integrated Device Technology, Inc.